

FORM 2

**THE PATENTS ACT, 1970
(39 of 1970)**

&

THE PATENTS RULES, 2003

**COMPLETE SPECIFICATION
(See section 10, rule 13)**

**“MULTI-SENSOR PATIENT MONITOR TO DETECT IMPENDING
CARDIAC DECOMPENSATION”**

CORVENTIS INC., 2226 North First Street, San Jose, California 95131, United States of America, a company incorporated in United States of America.

The following specification particularly describes the invention and the manner in which it is to be performed.

MULTI-SENSOR PATIENT MONITOR TO DETECT IMPENDING CARDIAC DECOMPENSATION

CROSS-REFERENCES TO RELATED APPLICATIONS

[0001] The present application claims the benefit under 35 USC 119(e) of U.S. Provisional Application Nos. 60/972,512 and 60/972,537 both filed Sep. 14, 2007, and 61/055,666 filed May 23, 2008; the full disclosures of which are incorporated herein by reference in their entirety.

BACKGROUND OF THE INVENTION

[0002] 1. Field of the Invention

The present invention relates to patient monitoring, and more specifically to patient monitoring to detect and/or avoid impending cardiac decompensation. Although embodiments make specific reference to monitoring impedance and electrocardiogram signals with an adherent patch, the system methods and device described herein may be applicable to many applications in which physiological monitoring is used, for example wireless physiological monitoring with implantable devices for extended periods.

[0003] Patients are often treated for diseases and/or conditions associated with a compromised status of the patient, for example a compromised physiologic status such as heart disease. In some instances a patient may have suffered a heart attack and require care and/or monitoring after release from the hospital. While such long term care may be at least partially effective, many patients are not sufficiently monitored and eventually succumb to cardiac decompensation, or heart failure. One example of a device that may be used to monitor a patient is the Holter monitor, or ambulatory electrocardiography device. Although such a device may be effective in measuring electrocardiography, such measurements alone may not be sufficient to reliably detect and/or avoid an impending cardiac decompensation.

[0004] In addition to measuring heart signals with electrocardiograms, known physiologic measurements include impedance measurements. For example, transthoracic impedance measurements can be used to measure hydration and respiration. Although transthoracic measurements can be useful, such measurements may use electrodes that are positioned across the midline of the patient, and may be somewhat uncomfortable and/or cumbersome for the patient to wear.

[0005] Work in relation to embodiments of the present invention suggests that known methods and apparatus for long term monitoring of patients may be less than ideal to detect

and/or avoid an impending cardiac decompensation. In at least some instances, cardiac decompensation can be difficult to detect, for example in the early stages. At least some of the known devices may not collect the right kinds of data to treat patients optimally. For example, although successful at detecting and storing electrocardiogram signals, devices such as the Holter monitor can be somewhat bulky and may not collect all of the kinds of data that would be ideal to diagnose and/or treat a patient, for example to detect decompensation. In at least some instances, devices that are worn by the patient may be somewhat uncomfortable, which may lead to patients not wearing the devices and not complying with direction from the health care provider, such that data collected may be less than ideal. Although implantable devices may be used in some instances, many of these devices can be invasive and/or costly, and may suffer at least some of the shortcomings of known wearable devices. As a result, at least some patient are not adequately monitored, and may go into cardiac decompensation, or even die. Work in relation to embodiments of the present invention suggests that improved monitoring may avoid patient trauma, save lives, and decrease health care costs.

[0006] Therefore, a need exists for improved patient monitoring. Ideally, such improved patient monitoring would avoid at least some of the short-comings of the present methods and devices.

[0007] 2. Description of the Background Art: The following U.S. Patents and Publications may describe relevant background art: U.S. Pat. Nos. 4,121,573; 4,955,381; 4,981,139; 5,080,099; 5,353,793; 5,469,859; 5,511,553; 5,544,661; 5,558,638; 5,724,025; 5,772,586; 5,862,802; 6,047,203; 6,117,077; 6,129,744; 6,225,901; 6,308,094; 6,385,473; 6,416,471; 6,454,707; 6,454,708; 6,527,711; 6,527,729; 6,551,252; 6,595,927; 6,595,929; 6,605,038; 6,645,153; 6,821,249; 6,980,851; 7,020,508; 7,054,679; 7,153,262; 7,160,252; 2004/133079; 2004/152956; 2005/0113703; 2005/0131288; 2006/0010090; 2006/0031102; 2006/0089679; 2006/122474; 2006/0155183; 2006/0224051; 2006/0264730; 2007/0021678; 2007/0038038; 2005/256418; 2005/137626; and 2006/161459. The following PCT Publication(s) may also describe relevant background art: WO2006/111878.

BRIEF SUMMARY OF THE INVENTION

[0008] Embodiments of the present invention provide systems and methods for the detection of an impending cardiac decompensation. In many embodiments, the impending decompensation can be detected early enough to avoid, or at least delay, the impending decompensation, such that patient trauma and/or expensive ICU care can be avoided.

Although embodiments make specific reference to monitoring impedance and electrocardiogram signals with an adherent patch, the system methods and device described herein may be applicable to many applications in which physiological monitoring is used, for example wireless physiological monitoring with implanted sensors for extended periods.

[0009] In a first aspect, embodiments of the present invention provide a method of detecting an impending cardiac decompensation of a patient. At least two of an electrocardiogram signal of the patient, a hydration signal of the patient, a respiration signal of the patient or an activity signal of the patient are measured. The at least two of the electrocardiogram signal, the hydration signal, the respiration signal or the activity signal are combined to detect the impending cardiac decompensation. In many embodiments, the impending decompensation can be detected at least 24 hours before the decompensation occurs, for example 72 hours, and in many embodiments with a confidence level of at least 80%, for example 90%.

[0010] In many embodiments, the at least two comprise at least three of the electrocardiogram signal, the hydration signal, the respiration signal or the activity signal, and the at least three are measured and combined to detect the impending cardiac decompensation. In specific embodiments, the at least three comprise at least four of the electrocardiogram signal, the hydration signal, the respiration signal or the activity signal, and the at least four are measured and combined to detect the impending cardiac decompensation.

[0011] In specific embodiments, the electrocardiogram signal, the hydration signal, the respiration signal and the activity signal are measured combined to detect the impending cardiac decompensation.

[0012] In many embodiments, the at least two of the electrocardiogram signal, the hydration signal, the respiration signal or the activity signal can be used simultaneously to determine impending cardiac decompensation. The at least two signals can be used simultaneously in many ways.

[0013] In many embodiments, combining comprises using the at least two of the electrocardiogram signal, the hydration signal, the respiration signal or the activity signal to look up a value in a previously existing array. In some embodiments, combining may comprise at least one of adding, subtracting, multiplying, scaling or dividing the at least two of the electrocardiogram signal, the hydration signal, the respiration signal or the activity signal. In some embodiments, the at least two of the electrocardiogram signal, the hydration signal, the respiration signal or the activity signal can be combined with at least one of a

weighted combination, a tiered combination or a logic gated combination, a time weighted combination or a rate of change.

[0014] In many embodiments, a flag status is determined in response to the at least two of the electrocardiogram signal, the hydration signal, the respiration signal or the activity signal. The flag status can be determined in response to a change in the at least two of the electrocardiogram signal, the hydration signal, the respiration signal or the activity signal. In some embodiments, additional signal measurements of the patient can be made in response to the flag status.

[0015] In many embodiments, the at least two of the electrocardiogram signal, the hydration signal, the respiration signal or the activity signal are combined in response to a time of day.

[0016] In many embodiments, the at least two of the electrocardiogram signal, the hydration signal, the respiration signal or the activity signal may comprise at least one of a derived signal, a time averaged signal, a filtered signal or a raw signal.

[0017] In many embodiments, baseline values of the patient for the at least two of the electrocardiogram signal, the hydration signal, the respiration signal or the activity signal are determined, and the at least two of the electrocardiogram signal, the hydration signal, the respiration signal or the activity signal signals comprise changes from the baseline values.

[0018] In many embodiments, the at least two of the electrocardiogram signal, the hydration signal, the respiration signal or the activity signal comprise differences from population baseline values, and the impending decompensation is detected in response to the differences from the baseline values of the patient population.

[0019] In many embodiments, the hydration signal comprises an impedance signal and the activity signal comprise an accelerometer signal.

[0020] In many embodiments, the activity signal may comprise an accelerometer signal to indicate a posture of the patient. In specific embodiments, the accelerometer signal may comprise a three-dimensional inclination signal to determine a three dimensional orientation of the patient.

[0021] In many embodiments, a temperature signal is combined with the at least two of the electrocardiogram signal, the hydration signal, the respiration signal or the activity signal to detect the impending cardiac decompensation.

[0022] In many embodiments, the at least two of the electrocardiogram signal, the hydration signal, the respiration signal or the activity signal are transmitted to a remote site

where the at least two of the electrocardiogram signal, the hydration signal, the respiration signal or the activity signal are combined to detect the impending cardiac decompensation.

[0023] In many embodiments, instructions are transmitted from a remote site to a processor supported with the patient, and the at least two of the electrocardiogram signal, the hydration signal, the respiration signal or the activity signal are combined with the processor in response to the instructions to detect the impending cardiac decompensation.

[0024] In another aspect, embodiments of the present invention provide a system to detect impending cardiac decompensation of a patient. The system comprises circuitry to measure at least two of an electrocardiogram signal of the patient, a hydration signal of the patient, or an activity signal of the patient. A processor system comprising a tangible medium in communication with the circuitry is configured to combine the at least two of the electrocardiogram signal, the hydration signal, the respiration signal or the activity signal to detect the impending cardiac decompensation.

[0025] In some embodiments, the processor system comprises a least one processor remote from the patient configured to combine the at least two to detect the decompensation.

[0026] In some embodiments, the processor system comprises a processor supported with the patient configured to receive instructions transmitted from a remote site and combine the at least two in response to the instructions to detect the impending cardiac decompensation.

[0027] In many embodiments, the at least two comprise at least three of the electrocardiogram signal, the hydration signal, the respiration signal or the activity signal and the at least three are measured and combined to detect the impending cardiac decompensation. In specific embodiments, the at least three comprise at least four of the electrocardiogram signal, the hydration signal, the respiration signal or the activity signal and the at least four are measured and combined to detect the impending cardiac decompensation.

[0028] In specific embodiments, the processor system simultaneously uses the at least two of the electrocardiogram signal, the hydration signal, the respiration signal or the activity signal to determine impending cardiac decompensation. The at least two signals can be used simultaneously in many ways,

[0029] In many embodiments, combining comprises the processor system using the at least two of the electrocardiogram signal, the hydration signal, the respiration signal or the activity signal to look up a value in a previously existing array. In some embodiments, combining comprises at least one of adding, subtracting, multiplying, scaling or dividing the at least two of the electrocardiogram signal, the hydration signal, the respiration signal or the activity signal. In some embodiments, the at least two of the electrocardiogram signal, the

hydration signal, the respiration signal, or the activity signal can be combined with at least one of a weighted combination, a tiered combination or a logic gated combination, a time weighted combination or a rate of change.

[0030] In many embodiments, the processor system determines a flag status in response to the at least two of the electrocardiogram signal, the hydration signal, the respiration signal or the activity signal. The processor system determines the flag status in response to a change in the at least two of the electrocardiogram signal, the hydration signal, the respiration signal or the activity signal. In some embodiments, the processor system affects the circuitry to make additional signal measurements of the patient in response to the flag status.

[0031] In many embodiments, the processor system combines the at least two of the electrocardiogram signal, the hydration signal, the respiration signal or the activity signal in response to a time of day.

[0032] In many embodiments, the at least two of the electrocardiogram signal, the hydration signal, the respiration signal or the activity signal comprise at least one of a derived signal, a time averaged signal, a filtered signal or a raw signal.

[0033] In many embodiments, the processor determines baseline values of the patient for the at least two of the electrocardiogram signal, the hydration signal, the respiration signal or the activity signal. The at least two of the electrocardiogram signal, the hydration signal, the respiration signal or the activity signal signals may comprise changes from the baseline values.

[0034] In many embodiments, the at least two of the electrocardiogram signal, the hydration signal, the respiration signal or the activity signal comprise differences from baseline values of a patient population. The impending decompensation is detected in response to the differences from the baseline value of the patient population.

[0035] In many embodiments, the hydration signal comprises an impedance signal and the activity signal comprise an accelerometer signal.

[0036] In many embodiments, the activity signal may comprise an accelerometer signal to determine a posture of the patient. In specific embodiments, the accelerometer signal may comprise a three-dimensional inclination signal to determine a three dimensional orientation of the patient.

[0037] In many embodiments, the processor system combines a temperature signal with the at least two of the electrocardiogram signal, the hydration signal, the respiration signal or the activity signal to detect the impending cardiac decompensation.

[0038] In many embodiments, the processor transmits the at least two of the electrocardiogram signal, the hydration signal, the respiration signal or the activity signal to a remote site where the at least two of the electrocardiogram signal, the hydration signal, the respiration signal or the activity signal are combined to detect the impending cardiac decompensation.

[0039] In many embodiments, instructions are transmitted from a remote site to a processor supported with the patient. The processor combines at least two of the electrocardiogram signal, the hydration signal, the respiration signal or the activity signal in response to the instructions to detect the impending cardiac decompensation

BRIEF DESCRIPTION OF THE DRAWINGS

[0040] FIG. 1A shows a patient and a monitoring system comprising an adherent device, according to embodiments of the present invention;

[0041] FIG. 1B shows a bottom view of the adherent device as in FIG. 1A comprising an adherent patch;

[0042] FIG. 1C shows a top view of the adherent patch, as in FIG. 1B;

[0043] FIG. 1D shows a printed circuit boards and electronic components over the adherent patch, as in FIG. 1C;

[0044] FIG. 1D-1 shows an equivalent circuit that can be used to determine optimal frequencies for determining patient hydration, according to embodiments of the present invention;

[0045] FIG. 1E shows batteries positioned over the printed circuit board and electronic components as in FIG. 1D;

[0046] FIG. 1F shows a top view of an electronics housing and a breathable cover over the batteries, electronic components and printed circuit board as in FIG. 1E;

[0047] FIG. 1G shows a side view of the adherent device as in FIGS. 1A to 1F;

[0048] FIG. 1H shown a bottom isometric view of the adherent device as in FIGS. 1A to 1G;

[0049] FIG. 2A shows a method of predicting an impending cardiac decompensation, according to embodiments of the present invention; and

[0050] FIGS. 3A and 3B show clinical data measured with an adherent patch device.

DETAILED DESCRIPTION OF THE INVENTION

[0051] Embodiments of the present invention provide systems and methods for the detection of an impending cardiac decompensation. In many embodiments, the impending decompensation can be detected early enough to avoid, or at least delay, the impending decompensation, such that patient trauma and/or expensive ICU care can be avoided. Although embodiments make specific reference to monitoring impedance and electrocardiogram signals with an adherent patch, the system methods and device described herein may be applicable to many applications in which physiological monitoring is used, for example wireless physiological monitoring with implanted sensors for extended periods. In some embodiments, implanted sensors may be used, for example as described in U.S. Pat. Nos. 6,208,894; 6,315,721; 6,185,452; and U.S. Application No. 60/972,329, entitled “Injectable Device for Physiological Monitoring” filed on Sep. 14, 2007, the same day as the present application with the same assignee, the full disclosures of which are incorporated by reference.

[0052] Decompensation is failure of the heart to maintain adequate blood circulation. Although the heart can maintain at least some pumping of blood, the quantity is inadequate to maintain healthy tissues. Several symptoms can result from decompensation including pulmonary congestion, breathlessness, faintness, cardiac palpitation, edema of the extremities, and enlargement of the liver. Cardiac decompensation can result in slow or sudden death. Sudden Cardiac Arrest (hereinafter “SCA”), also referred to as sudden cardiac death, is an abrupt loss of cardiac pumping function that can be caused by a ventricular arrhythmia, for example ventricular tachycardia and/or ventricular fibrillation. Although decompensation and SCA can be related in that patients with decompensation are also at an increased risk for SCA, decompensation is primarily a mechanical dysfunction caused by inadequate blood flow, and SCA is primarily an electrical dysfunction caused by inadequate and/or inappropriate electrical signals of the heart.

[0053] FIG. 1A shows a patient P and a monitoring system **10**. Patient P comprises a midline M, a first side S1, for example a right side, and a second side S2, for example a left side. Monitoring system **10** comprises an adherent device **100**. Adherent device **100** can be adhered to a patient P at many locations, for example thorax T of patient P. In many embodiments, the adherent device may adhere to one side of the patient, from which data from the one side can be collected. Work in relation with embodiments of the present invention suggests that location on a side of the patient can provide comfort for the patient while the device is adhered to the patient.

[0054] Monitoring system **10** includes components to transmit data to a remote center **106**. Adherent device **100** can communicate wirelessly to an intermediate device **102**, for example with a single wireless hop from the adherent device on the patient to the intermediate device. Intermediate device **102** can communicate with remote center **106** in many ways, for example with an internet connection. In many embodiments, monitoring system **10** comprises a distributed processing system with at least one processor on device **100**, at least one processor on intermediate device **102**, and at least one process at remote center **106**, each of which processors is in electronic communication with the other processors. Remote center **106** can be in communication with a health care provider **108A** with a communication system **107A**, such as the Internet, an intranet, phone lines, wireless and/or satellite phone. Health care provider **108A**, for example a family member, can be in communication with patient P with a communication, for example with a two way communication system, as indicated by arrow **109A**, for example by cell phone, email, landline. Remote center **106** can be in communication with a health care professional, for example a physician **108B**, with a communication system **107B**, such as the Internet, an intranet, phone lines, wireless and/or satellite phone. Physician **108B** can be in communication with patient P with a communication, for example with a two way communication system, as indicated by arrow **109B**, for example by cell phone, email, landline. Remote center **106** can be in communication with an emergency responder **108C**, for example a 911 operator and/or paramedic, with a communication system **107C**, such as the Internet, an intranet, phone lines, wireless and/or satellite phone. Emergency responder **108C** can travel to the patient as indicated by arrow **109C**. Thus, in many embodiments, monitoring system **10** comprises a closed loop system in which patient care can be monitored and implemented from the remote center in response to signals from the adherent device.

[0055] In many embodiments, the adherent device may continuously monitor physiological parameters, communicate wirelessly with a remote center, and provide alerts when necessary. The system may comprise an adherent patch, which attaches to the patient's thorax and contains sensing electrodes, battery, memory, logic, and wireless communication capabilities. In some embodiments, the patch can communicate with the remote center, via the intermediate device in the patient's home. In the many embodiments, the remote center receives the data and applies the prediction algorithm. When a flag is raised, the center may communicate with the patient, hospital, nurse, and/or physician to allow for therapeutic intervention to prevent decompensation.

[0056] The adherent device may be affixed and/or adhered to the body in many ways. For example, with at least one of the following an adhesive tape, a constant-force spring, suspenders around shoulders, a screw-in microneedle electrode, a pre-shaped electronics module to shape fabric to a thorax, a pinch onto roll of skin, or transcutaneous anchoring. Patch and/or device replacement may occur with a keyed patch (e.g. two-part patch), an outline or anatomical mark, a low-adhesive guide (place guide |remove old patch |place new patch |remove guide), or a keyed attachment for chatter reduction. The patch and/or device may comprise an adhesiveless embodiment (e.g. chest strap), and/or a low-irritation adhesive model for sensitive skin. The adherent patch and/or device can comprise many shapes, for example at least one of a dogbone, an hourglass, an oblong, a circular or an oval shape.

[0057] In many embodiments, the adherent device may comprise a reusable electronics module with replaceable patches (the module collects cumulative data for approximately 90 days) and/or the entire adherent component (electronics + patch) may be disposable. In a completely disposable embodiment, a “baton” mechanism may be used for data transfer and retention, for example baton transfer may include baseline information. In some embodiments, the device may have a rechargeable module, and may use dual battery and/or electronics modules, wherein one module **101A** can be recharged using a charging station **103** while the other module **101B** is placed on the adherent device. In some embodiments, the intermediate device **102** may comprise the charging module, data transfer, storage and/or transmission, such that one of the electronics modules can be placed in the intermediate device for charging and/or data transfer while the other electronics module is worn by the patient.

[0058] In many embodiments, the system can perform the following functions: initiation, programming, measuring, storing, analyzing, communicating, predicting, and displaying. The adherent device may contain a subset of the following physiological sensors: bioimpedance, respiration, respiration rate variability, heart rate (average, minimum, maximum), heart rhythm, HRV, HRT, heart sounds (e.g. S3), respiratory sounds, blood pressure, activity, posture, wake/sleep, orthopnea, temperature/heat flux, and weight. The activity sensor may be one of the following: ball switch, accelerometer, minute ventilation, HR, bioimpedance noise, skin temperature/heat flux, BP, muscle noise, posture.

[0059] In many embodiments, the patch wirelessly communicates with a remote center. In some embodiments, the communication may occur directly (via a cellular or Wi-Fi network), or indirectly through intermediate device **102**. Intermediate device **102** may consist

of multiple devices which communicate wired or wirelessly to relay data to remote center **106**.

[0060] FIG. 1B shows a bottom view of adherent device **100** as in FIG. 1A comprising an adherent patch **110**. Adherent patch **110** comprises a first side, or a lower side **110A**, that is oriented toward the skin of the patient when placed on the patient. In many embodiments, adherent patch **110** comprises a tape **110T** which is a material, preferably breathable, with an adhesive **116A**. Patient side **110A** comprises adhesive **116A** to adhere the patch **110** and adherent device **100** to patient P. Electrodes **112A**, **112B**, **112C** and **112D** are affixed to adherent patch **110**. In many embodiments, at least four electrodes are attached to the patch, for example six electrodes. In some embodiments the patch comprises at least two electrodes, for example two electrodes to measure an electrocardiogram (ECG) of the patient. Gel **114A**, gel **114B**, gel **114C** and gel **114D** can each be positioned over electrodes **112A**, **112B**, **112C** and **112D**, respectively, to provide electrical conductivity between the electrodes and the skin of the patient. In many embodiments, the electrodes can be affixed to the patch **110**, for example with known methods and structures such as rivets, adhesive, stitches, etc. In many embodiments, patch **110** comprises a breathable material to permit air and/or vapor to flow to and from the surface of the skin.

[0061] FIG. 1C shows a top view of the adherent patch **100**, as in FIG. 1B. Adherent patch **100** comprises a second side, or upper side **110B**. In many embodiments, electrodes **110A**, **110B**, **110C** and **110D** extend from lower side **110A** through the adherent patch to upper side **110B**. In some embodiments, an adhesive **116B** can be applied to upper side **110B** to adhere structures, for example, a cover, to the patch such that the patch can support the electronics and other structures when the patch is adhered to the patient. The printed circuit board (PCB) comprise completely flex PCB, rigid PCB combined flex PCB and/or rigid PCB boards connected by cable.

[0062] FIG. 1D shows a printed circuit boards and electronic components over adherent patch **110**, as in FIG. 1C. A printed circuit board (PCB), for example flex PCB **120**, can be positioned above **110B** of patch **110**. Flex PCB **120** can include traces that extends to connectors **122A**, **122B**, **122C** and **122D** on the flex PCB. Connectors **122A**, **122B**, **122C** and **122D** can be positioned on flex PCB **120** in alignment with electrodes **112A**, **112B**, **112C** and **112D** so as to electrically couple the flex PCB with the electrodes. In some embodiments, connectors **122A**, **122B**, **122C** and **122D** may comprise insulated wires or a flex circuit that provide strain relief between the PCB and the electrodes. In some embodiments, additional PCB's for example PCB **120A**, **120B**, **120C** and **120D** be connected to flex PCB **120**.

Electronic components **130** can be connected to flex PCB **120** and/or mounted thereon. In some embodiments, electronic components **130** can be mounted on the additional PCB's.

[0063] Electronic components **130** comprise components to take physiologic measurements, transmit data to remote center **106** and receive commands from remote center **106**. In many embodiments, electronics components **130** may comprise known low power circuitry, for example complementary metal oxide semiconductor (CMOS) circuitry components. Electronics components **130** comprise an activity sensor and activity circuitry **134**, impedance circuitry **136** and electrocardiogram circuitry, for example ECG circuitry **136**. In some embodiments, electronics circuitry **130** may comprise a microphone and microphone circuitry **142** to detect an audio signal from within the patient, and the audio signal may comprise a heart sound and/or a respiratory sound, for example an S3 heart sound and a respiratory sound with rales and/or crackles. Electronics circuitry **130** may comprise a temperature sensor, for example a thermistor, and temperature sensor circuitry **144** to measure a temperature of the patient, for example a temperature of a skin of the patient. Electronics circuitry may comprise a heat flux sensor and heat flux sensor circuitry to measure a skin heat flow of a patient.

[0064] Work in relation to embodiments of the present invention suggests that skin temperature may effect impedance and/or hydration measurements, and that skin temperature measurements may be used to correct impedance and/or hydration measurements. In some embodiments, increase in skin temperature can be associated with increased vaso-dilation near the skin surface, such that measured impedance measurement decreased, even through the hydration of the patient in deeper tissues under the skin remains substantially unchanged. Thus, use of the temperature sensor can allow for correction of the hydration signals to more accurately assess the hydration, for example extra cellular hydration, of deeper tissues of the patient, for example deeper tissues in the thorax.

[0065] Electronics circuitry **130** may comprise a processor **146**. Processor **146** comprises a tangible medium, for example read only memory (ROM), electrically erasable programmable read only memory (EEPROM) and/or random access memory (RAM). Electronic circuitry **130** may comprise real time clock and frequency generator circuitry **148**. In some embodiments, processor **136** may comprise the frequency generator and real time clock. The processor can be configured to control a collection and transmission of data from the impedance circuitry electrocardiogram circuitry and the accelerometer. In many embodiments, device **100** comprise a distributed processor system, for example with multiple processors on device **100**.

[0066] In many embodiments, electronics components **130** comprise wireless communications circuitry **132** to communicate with remote center **106**. The wireless communication circuitry can be coupled to the impedance circuitry, the electrocardiogram circuitry and the accelerometer to transmit to a remote center with a communication protocol at least one of the hydration signal, the electrocardiogram signal or the accelerometer signal. In specific embodiments, wireless communication circuitry is configured to transmit the hydration signal, the electrocardiogram signal and the accelerometer signal to the remote center with a single wireless hop, for example from wireless communication circuitry **132** to intermediate device **102**. The communication protocol comprises at least one of Bluetooth, Zigbee, WiFi, WiMax, IR, amplitude modulation or frequency modulation. In many embodiments, the communications protocol comprises a two way protocol such that the remote center is capable of issuing commands to control data collection.

[0067] In some embodiments, intermediate device **102** comprises a data collection system to collect and store data from the wireless transmitter. The data collection system can be configured to communicate periodically with the remote center. In many embodiments, the data collection system can transmit data in response to commands from remote center **106** and/or in response to commands from the adherent device.

[0068] Activity sensor and activity circuitry **134** can comprise many known activity sensors and circuitry. In many embodiments, the accelerometer comprises at least one of a piezoelectric accelerometer, capacitive accelerometer or electromechanical accelerometer. The accelerometer may comprise a 3-axis accelerometer to measure at least one of an inclination, a position, an orientation or acceleration of the patient in three dimensions. Work in relation to embodiments of the present invention suggests that three dimensional orientation of the patient and associated positions, for example sitting, standing, lying down, can be very useful when combined with data from other sensors, for example ECG data and/or hydration data.

[0069] Impedance circuitry **136** can generate both hydration data and respiration data. In many embodiments, impedance circuitry **136** is electrically connected to electrodes **112A**, **112B**, **112C** and **112D** such that electrodes **112A** and **112D** comprise outer electrodes that are driven with a current, or force electrodes. The current delivered between electrodes **112A** and **112D** generates a measurable voltage between electrodes **112B** and **112C**, such that electrodes **112B** and **112C** comprise inner electrodes, or sense electrodes that measure the voltage in response to the current from the force electrodes. The voltage measured by the sense electrodes can be used to determine the hydration of the patient.

[0070] FIG. 1D-1 shows an equivalent circuit **152** that can be used to determine optimal frequencies for measuring patient hydration. Work in relation to embodiments of the present invention indicates that the frequency of the current and/or voltage at the force electrodes can be selected so as to provide impedance signals related to the extracellular and/or intracellular hydration of the patient tissue. Equivalent circuit **152** comprises an intracellular resistance **156**, or R(ICW) in series with a capacitor **154**, and an extracellular resistance **158**, or R(ECW). Extracellular resistance **158** is in parallel with intracellular resistance **156** and capacitor **154** related to capacitance of cell membranes. In many embodiments, impedances can be measured and provide useful information over a wide range of frequencies, for example from about 0.5 kHz to about 200 KHz. Work in relation to embodiments of the present invention suggests that extracellular resistance **158** can be significantly related extracellular fluid and to cardiac decompensation, and that extracellular resistance **158** and extracellular fluid can be effectively measured with frequencies in a range from about 0.5 kHz to about 20 kHz, for example from about 1 kHz to about 10 kHz. In some embodiments, a single frequency can be used to determine the extracellular resistance and/or fluid. As sample frequencies increase from about 10 kHz to about 20 kHz, capacitance related to cell membranes decrease the impedance, such that the intracellular fluid contributes to the impedance and/or hydration measurements. Thus, many embodiments of the present invention employ measure hydration with frequencies from about 0.5 kHz to about 20 kHz to determine patient hydration.

[0071] In many embodiments, impedance circuitry **136** can be configured to determine respiration of the patient. In specific embodiments, the impedance circuitry can measure the hydration at 25 Hz intervals, for example at 25 Hz intervals using impedance measurements with a frequency from about 0.5 kHz to about 20 kHz.

[0072] ECG circuitry **138** can generate electrocardiogram signals and data from electrodes **112A**, **112B**, **112C** and **112D**. In some embodiments, ECG circuitry **138** is connected to inner electrodes **12B** and **122C**, which may comprise sense electrodes of the impedance circuitry as described above. In some embodiments, the inner electrodes may be positioned near the outer electrodes to increase the voltage of the ECG signal measured by ECG circuitry **138**. In some embodiments, the ECG circuitry can share components with the impedance circuitry.

[0073] FIG. 1E shows batteries **150** positioned over the flex printed circuit board and electronic components as in FIG. 1D. Batteries **150** may comprise rechargeable batteries that

can be removed and/or recharged. In some embodiments, batteries **150** can be removed from the adherent patch and recharged and/or replaced.

[0074] FIG. 1F shows a top view of a cover **162** over the batteries, electronic components and flex printed circuit board as in FIG. 1E. In many embodiments, an electronics housing **160** may be disposed under cover **162** to protect the electronic components, and in some embodiments electronics housing **160** may comprise an encapsulant over the electronic components and PCB. In many embodiments, electronics housing **160** may comprise a water proof material, for example a sealant adhesive such as epoxy or silicone coated over the electronics components and/or PCB. In some embodiments, electronics housing **160** may comprise metal and/or plastic, which may be potted with silicone, epoxy, etc.

[0075] Cover **162** may comprise many known biocompatible cover, casing and/or housing materials, such as elastomers, for example silicone. The elastomer may be fenestrated to improve breathability. In some embodiments, cover **162** may comprise many known breathable materials, for example polyester or polyamide fabric. The breathable fabric may be coated to make it water resistant, waterproof, and/or to aid in wicking moisture away from the patch. The breathable fabric may be coated in order to make the outside hydrophobic and the inside hydrophilic.

[0076] FIG. 1G shows a side view of adherent device **100** as in FIGS. 1A to 1F. Adherent device **100** comprises a maximum dimension, for example a length **170** from about 4 to 10 inches (from about 100 mm to about 250 mm), for example from about 6 to 8 inches (from about 150 mm to about 200 mm). In some embodiments, length **170** may be no more than about 6 inches (no more than about 150 mm). Adherent device **100** comprises a thickness **172**. Thickness **172** may comprise a maximum thickness along a profile of the device. Thickness **172** can be from about 0.2 inches to about 0.4 inches (from about 5 mm to about 10 mm), for example about 0.3 inches (about 7.5 mm).

[0077] FIG. 1H shown a bottom isometric view of adherent device **100** as in FIGS. 1A to 1G. Adherent device **100** comprises a width **174**, for example a maximum width along a width profile of adherent device **100**. Width **174** can be from about 2 to about 4 inches (from about 50 mm to 100 mm), for example about 3 inches (about 75 mm).

[0078] FIG. 2A shows a method **200** of predicting an impending cardiac decompensation. A step **205** measures an ECG signal. The ECG signal may comprise a differential signal measured with at least two electrodes and may be measured in many known ways. A step **210** measures an hydration signal. The hydration signal may comprise an impedance signal, for example a four pole impedance signal, and may be measured in many known

ways. A step **215** measures a respiration signal. The respiration signal may comprise an impedance signal, and may be measured in many known ways. A step **220** measures an activity signal. The activity signal may be measured in many known ways and may comprise a three-dimensional accelerometer signal to determine a position of the patient, for example from a three dimensional accelerometer signal. A step **225** measures a temperature signal. The temperature signal may be measured in many ways, for example with a thermistor, a thermocouple, and known temperature measurement devices. A step **230** records a time of day of the signals, for example a local time of day such as morning, afternoon, evening, and/or nighttime.

[0079] A step **235** processes the signals. The signals may be processed in many known ways, for example to generate at least one of a derived signal, a time averaged signal, a filtered signal. In some embodiments, the signals may comprise raw signals. The ECG signal may comprise at least one of a heart rate signal, a heart rate variability signal, an average heart rate signal, a maximum heart rate signal or a minimum heart rate signal. The hydration signal may comprise an impedance measurement signal. The activity signal may comprise at least one of an accelerometer signal, a position signal indicating the orientation of the patient, such as standing, lying, or sitting. The respiration signal may comprise a least one of a respiration rate, a maximum respiration rate, a minimum respiration rate, an average respiration rate or respiration rate variability. The temperature may comprise an average temperature or a peak temperature.

[0080] A step **240** compares the signals with baseline values. In many embodiments, the baseline values may comprise measurements from the same patient at an earlier time. In some embodiments, the baseline values comprise values for a patient population. In some embodiments, the baseline values for a patient population may comprise empirical data from a suitable patient population size, for example at least about 144 patients, depending on the number of variables measured, statistical confidence and power used. The measured signals may comprise changes and/or deviations from the baseline values.

[0081] A step **245** transmits the signals. In many embodiments, the measurement signals, which may comprise derived and/or processed measurement signals, are transmitted to the remote site for comparison. In some embodiments, the signals may be transmitted to a processor supported with the patient for comparison.

[0082] A step **250** combines at least two of the ECG signal, the hydration signal, the respiration signal, the activity signal and the temperature signal to detect the impending decompensation. In many embodiments, at least three of the signals are combined. In some

embodiments, at least four signals comprising ECG signal, the hydration signal, the respiration signal and the activity signal are combined to detect the impending decompensation. In specific embodiments, at least four signals comprising the ECG signal, the hydration signal, the respiration signal, the activity signal and the temperature signal are combined to detect the impending decompensation.

[0083] The signals can be combined in many ways. In some embodiments, the signals can be used simultaneously to determine the impending cardiac decompensation.

[0084] In some embodiments, the signals can be combined by using the at least two of the electrocardiogram signal, the hydration signal, the respiration signal or the activity signal to look up a value in a previously existing array.

[0085] TABLE 1:Lookup Table for ECG and Hydration Signals

<i>Heart Rate/Hydration</i>	<i>0-49 bpm</i>	<i>50-69 bpm</i>	<i>70-90 bpm</i>
>60 Ohms	N	N	Y
41-59 Ohms	N	Y	Y
0-40 Ohms	Y	Y	Y

[0086] Table 1 shows combination of the electrocardiogram signal with the hydration signal to look up a value in a pre-existing array. For example at a heart rate of 89 bpm and a hydration of 35 Ohms, the value in the table may comprise Y. In specific embodiments, the values of the look up table can be determined in response to empirical data measured for a patient population of at least about 100 patients, for example measurements on about 1000 to 10,000 patients.

[0087] In some embodiments, the table may comprise a three or more dimensional look up table.

[0088] In some embodiments, the signals may be combined with at least one of adding, subtracting, multiplying, scaling or dividing the at least two of the electrocardiogram signal, the hydration signal, the respiration signal or the activity signal. In specific embodiments, the measurement signals can be combined with positive and or negative coefficients determined in response to empirical data measured for a patient population of at least about 100 patients, for example data on about 1000 to 10,000 patients.

[0089] In some embodiments, a weighted combination may combine at least 3 measurement signals to generate an output value according to a formula of the general form

$$\text{OUTPUT} = aX + bY + cZ$$

where a, b and c comprise positive or negative coefficients determined from empirical data and X, Y and Z comprise measured signals for the patient, for example at least three of the electrocardiogram signal, the hydration signal, the respiration signal or the activity signal. While three coefficients and three variables are shown, the data may be combined with multiplication and/or division. One or more of the variables may be the inverse of a measure variable.

[0090] In some embodiments, the ECG signal comprises a heart rate signal that can be divided by the activity signal. Work in relation to embodiments of the present invention suggest that an increase in heart rate with a decrease in activity can indicate an impending decompensation. The signals can be combined to generate an output value with an equation of the general form

$$\text{OUTPUT} = aX/Y + bZ$$

where X comprise a heart rate signal, Y comprises a hydration rate signal and Z comprises a respiration signal, with each of the coefficients determined in response to empirical data as described above.

[0091] In some embodiments, the data may be combined with a tiered combination. While many tiered combinations can be used a tiered combination with three measurement signals can be expressed as

$$\text{OUTPUT} = (\Delta X) + (\Delta Y) + (\Delta Z)$$

where (ΔX) , (ΔY) , (ΔZ) may comprise change in heart rate signal from baseline, change in hydration signal from baseline and change in respiration signal from baseline, and each may have a value of zero or one, based on the values of the signals. For example if the heart rate increase by 10%, (ΔX) can be assigned a value of 1. If hydration increases by 5%, (ΔY) can be assigned a value of 1. If activity decreases below 10% of a baseline value (ΔZ) can be assigned a value of 1. When the output signal is three, a flag may be set to trigger an alarm.

[0092] In some embodiments, the data may be combined with a logic gated combination. While many logic gated combinations can be used a logic gated combination with three measurement signals can be expressed as

$$\text{OUTPUT} = (\Delta X) \text{ AND } (\Delta Y) \text{ AND } (\Delta Z)$$

where (ΔX) , (ΔY) , (ΔZ) may comprise change in heart rate signal from baseline, change in

hydration signal from baseline and change in respiration signal from baseline, and each may have a value of zero or one, based on the values of the signals. For example if the heart rate increase by 10%, (ΔX) can be assigned a value of 1. If hydration increases by 5%, (ΔY) can be assigned a value of 1. If activity decreases below 10% of a baseline value (ΔZ) can be assigned a value of 1. When each of (ΔX), (ΔY), (ΔZ) is one, the output signal is one, and a flag may be set to trigger an alarm. If any one of (ΔX), (ΔY) or (ΔZ) is zero, the output signal is zero and a flag may be set so as not to trigger an alarm. While a specific example with AND gates has been shown the data can be combined in many ways with known gates for example NAND, NOR, OR, NOT, XOR, XNOR gates. In some embodiments, the gated logic may be embodied in a truth table.

[0093] A step 255 sets a flag. The flag can be set in response to the output of the combined signals. In some embodiments, the flag may comprise a binary parameter in which a value of zero does not trigger an alarm and a value of one triggers an alarm.

[0094] A step 260 communicates with the patient and/or a health care provider. In some embodiments, the remote site may contact the patient to determine if he or she is okay and communicate the impending decompensation such that the patient can receive needed medical care. In some embodiments, the remote site contacts the health care provider to warn the provider of the impending decompensation and the need for the patient to receive medical care.

[0095] A step 265 collects additional measurements. Additional measurements may comprise additional measurements with the at least two signals, for example with greater sampling rates and or frequency of the measurements. Additional measurements may comprise measurements with additional sensors, for example an onboard microphone to detect at least one of rales, S1 heart sounds, S2 heart sounds, S3 heart sounds, or arrhythmias. In some embodiments, the additional measurements, for example sounds, can be transmitted to the health care provider to diagnose the patient in real time.

[0096] The processor system, as described above, can be configured to perform the method 200, including many of the steps described above. It should be appreciated that the specific steps illustrated in FIG. 2A provide a particular method of predicting an impending cardiac decompensation, according to an embodiment of the present invention. Other sequences of steps may also be performed according to alternative embodiments. For example, alternative embodiments of the present invention may perform the steps outlined above in a different order. Moreover, the individual steps illustrated in FIG. 2A may include multiple sub-steps that may be performed in various sequences as appropriate to the

individual step. Furthermore, additional steps may be added or removed depending on the particular applications. One of ordinary skill in the art would recognize many variations, modifications, and alternatives.

[0097] Experimental Clinical Study

[0098] The protocol below has been used to measure signals from actual patients with an adherent device. These data show that an adherent patch as described above can be continuously adhered for at least one week. These data also show that 90 day continuous in home monitoring can be achieved with a set of 13 patches in which one of the patches is replaced each week. The clinical testing device used an adherent device with modifications, as described more fully below and referred to as the MS system (multi-sensor). Although the clinical device did not include wireless circuitry and processor circuitry supported with the patch adhered to the skin of the patient, these data do show that such a device, as described above, can be made by one of ordinary skill in the art based on the teachings described herein. Additional empirical studies can be conducted on a suitable number of patients.

[0099] MS Clinical System Description

[00100] The MS clinical system includes many of the structure components described above. There is a flexible connection between the electrodes and the flex PCB, for example wires or polyurethane with silver ink. The cover can stretch with the breathable tape on both the clinical device and the above described wireless device. There is generally a gap between the flex PCB and breathable tape in both clinical and above described wireless devices. The tested device used weights to at least partially simulate the weight of wireless and processor circuitry. The adherent device of the MS clinical system comprises four electrodes to measure bioimpedance and ECG signals and a 3-axis accelerometer, as described above. Bioimpedance signals were used to determine patient respiration and patient hydration, and accelerometer signals were used to determine patient activity and posture. The MS clinical adherent patch device comprising the sensors and at least some sensor circuitry were connected to a processor to record data. The processor was connected to the tested adherent device with wires and supported away from the tested adherent patch device, for example around the patient's waist. Data were collected at regular intervals and uploaded to a remote site, as described above.

[00101] Clinical testing of the MS clinical system shows the effectiveness of the structures for continuous adherence of at least one week and data collection, and that patches can be successively removed and replaced by the patient for in-home monitoring. This effectiveness

has been shown without requiring fully functional electronics circuitry such as a battery, wireless circuitry and process circuitry on the adherent device. For example, the MS system includes an insert with about 20 g of additional weight. Although an insert with a 20 gram weight was used for the MS clinical device, greater amounts of weight and circuitry can be used, for example about 30-50 g. The patch device may be modified to accommodate additional weight, for example by increasing the size of the adherent surface. The shape of the MS clinical patch is generally elongate, similar to the elongate shape shown above.

[00102] Study Design and Rationale

[00103] The MS System is used in a clinical study of heart failure patients to gather data that can be used to develop an algorithm for diagnosing and predicting impending heart failure decompensation events. Events typically manifest as heart failure-related hospitalization, emergency room or urgent care visits leading to a change in oral or IV diuretic treatment.

[00104] The purpose of the clinical study is to correlate physiological signals recorded by the system to clinical events of acute heart failure decompensation (AHFD). Signals from the patch can be weighted and combined to determine an index that associates physiologic parameters to impending events of decompensation. Patients who have been classified as New York Heart Association class III and IV within the last 12 months and have had a recent AHFD event can be enrolled into the study and are monitored with the MS system for approximately 90 days.

[00105] AHFD events are defined as any of the following:

1) Any heart failure related ER, Urgent Care, in-office visit or hospitalization requiring administration of IV diuretics, administration of IV inotropes, or ultrafiltration for fluid removal.

2) A change in diuretic, defined as a change in diuretic directed by the health care provider occurring inside a hospital, emergency room, or urgent care setting (i.e. no patient self-directed changes to medications not approved by a health care provider would be included), that satisfies one or more of the following: a) a change in the type of diuretic the patient is taking, b) a dose increase of an existing diuretic, or c) the addition of another diuretic.

3) A heart failure decompensation event for which death is the outcome.

[00106] Patients enrolled in the study were asked to replace the patch weekly. The study can enroll at least about 550 patients. The patient was provided with a kit comprising 13

patches for replacement. The patches were placed on alternating left and right sides of the patient's thorax, as described above, to minimize progressive irritation.

[00107] The data collected in the study can be used to develop an algorithm to at least one of detect, diagnose or predict an impending cardiac decompensation. The algorithm can be implemented on a processor system as described above. Known methods can be used to analyze the data, for example splitting the patients into two groups, one to develop parameters for the algorithm and a second group to test the algorithm developed with the first group. In many embodiments, the signal of the algorithm may comprise a simple binary output for impending cardiac decompensation of the patient. The logic output, yes or no, can be determined in response to patient data combined as described above. The logic output may comprise a signal, such as a binary Y or N signal.

[00108] The developed algorithm can be evaluated with composite sensitivity and false positive patient signal status rates. The sensitivity may be defined as the percent of true positive events out of all condition present events, and the false positive patient status signal status rate can be defined as the number of false positive patient status signals per patient-years of follow up. For example, the sensitivity can be at least 50%, for example at least 60%, at least 70%, or even at least 80%. The false positive patient signal status rate may be limited to no more than about 1.1 false positive patient status signals per patient year, for example no more than about 1.0 false positive patient status signals per patient year, no more than about 0.9 false positive patient status signals per patient year, and even no more than about 0.8 false positive patient status signals per patient year.

[00109] Clinical Results

[00110] Clinical data are available for the first **180** patients enrolled in the study.

[00111] FIGS. 3A and 3B show clinical data measured with an adherent patch device, in accordance with the above protocol. FIG. 3A shows data from a patient with the MS patch adhered to a first patient, and the data was acquired over the 90 day period with the series of 13 patches. The signals measured included Heart Rate (beats per minute), Heart Rate Variability (ms), Respiratory Rate (breaths per minute), Activity (m-G's) and Body Fluid (Ohms). FIG. 3B shows data from a second patient similar to FIG. 3A.

[00112] Of the 180 patients who have completed the study with the MS adherent patch, as described above, all patches in all patients adhered continuously without patch failure. In all patients, the first patch adhered continuously for the first week. With the exception of a handful of patient deaths and early withdrawals that were unrelated to device failure, all patients reached the end of 90-day follow-up period having used 13 weekly patches without

incident. None of the 180 patients showed skin irritation or damage that required withdrawal from the study.

[00113] The above data show that the wireless adherent patch device can be constructed for in home wireless patient monitoring for an extended period of at least 90 day, in which each patch of a set is continuously adhered to a patient for at least one week and each patch is configured to support the measurement circuitry, the processor, the wireless communication circuitry and the battery with the skin of the patient.

[00114] While the exemplary embodiments have been described in some detail, by way of example and for clarity of understanding, those of skill in the art will recognize that a variety of modifications, adaptations, and changes may be employed. Hence, the scope of the present invention should be limited solely by the appended claims.

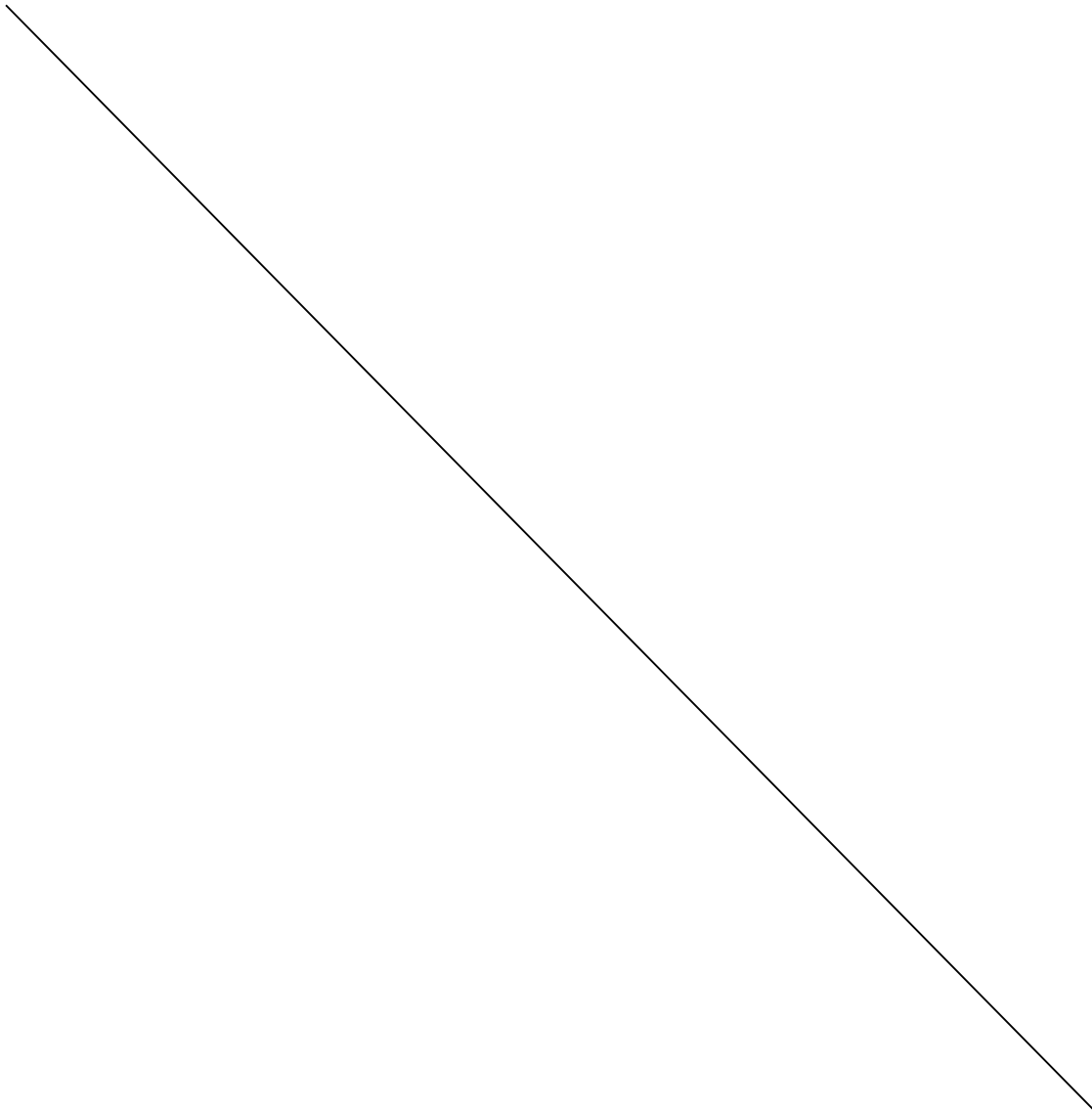

WE CLAIM:

1. A system to detect impending cardiac decompensation of a patient, the system comprising:
 - circuitry (130, 134, 136, 138, 152) to measure an impedance associated with the patient and a temperature of a skin of the patient; and
 - a processor system (100, 102, 106, or 146) comprising a tangible medium in communication with the circuitry (130, 134, 136, 138, 152), the processor system (100, 102, 106, or 146) configured to calculate a hydration measurement based on the measured impedance and corrects the calculated hydration measurements based on the measured skin temperature of the patient, wherein the processor system utilizes the corrected hydration measurement to detect the impending cardiac decompensation of the patient.

2. The system as claimed in claim 1, wherein the processor system (100, 102, 106, or 146) comprises a least one processor a location remote from the patient configured to detect the decompensation.

3. The system as claimed in claim 1, wherein the processor system (100, 102, 106, or 146), supported with the patient, receives instructions transmitted from a remote site and calculates the hydration measurement in response to the instructions to detect the impending cardiac decompensation.

4. The system as claimed in claim 1, wherein the circuitry (130, 134, 136, 138, 152) measures one or more of an electrocardiogram signal of the patient, a respiration signal, and an activity signal and combines the one or more measured signals with the corrected hydration measurement to detect the impending cardiac decompensation.

5. The system as claimed in claim 4, wherein two or more of the electrocardiogram signal, the hydration signal, the respiration signal or the activity signal are measured and combined with the corrected hydration measurement to detect the impending cardiac decompensation.

6. The system as claimed in claim 4, wherein the processor system (100, 102, 106, or 146) simultaneously uses the one or more of the electrocardiogram signal, the respiration signal or the activity signal in combination with the corrected hydration measurement to determine impending cardiac decompensation.

7. The system as claimed in claim 4, wherein the processor system (100, 102, 106, or 146) combines the one or more of the electrocardiogram signal, the respiration signal or the activity signal with the corrected hydration measurement in response to a time of day.

8. The system as claimed in claim 4, wherein the activity signal comprises an accelerometer signal to determine a posture of the patient.

9 The system as claimed in claim 8, wherein the accelerometer signal comprises a three-dimensional inclination signal to determine a three dimensional orientation of the patient.

10. The system as claimed in claim 4, wherein the processor transmits the one or more of the electrocardiogram signal, the respiration signal or the activity signal to a remote site where the one or more of the electrocardiogram signal, the respiration signal or the activity signal are combined with the corrected hydration signal to detect the impending cardiac decompensation.

11. The system as claimed in claim 4, comprising transmitting instructions from a remote site to a processor supported with the patient, and wherein the processor combines the one or more of the electrocardiogram signal, the hydration signal, the respiration signal or the activity signal with the corrected hydration signal in response to the instructions to detect the impending cardiac decompensation.

12. The system as claimed in claim 1, wherein the circuitry (130, 134, 136, 138, 152) places a voltage and/or current at one or more of electrodes connected to the circuitry (130, 134, 136, 138, 152) having a frequency between 0.5 kHz and about 20 kHz such that the hydration measurement corresponds to the extracellular fluid of the patient.

13. The system as claimed in claim 1, wherein the processor system (100, 102, 106, or 146) corrects the calculated hydration measurement by lowering the hydration measurement in response to an increase in measured skin temperature.

14. The system as claimed in claim 1, wherein the processor system (100, 102, 106, or 146) corrects the calculated hydration measurement by increasing the hydration measurement in response to a decrease in the measured skin temperature.

15. The system as claimed in claim 1, wherein the processor system (100, 102, 106, or 146) corrects the calculated hydration measurement such that the hydration measurement remains substantially unchanged when the measured impedance decreases and the skin temperature increases.

Dated this 26th day of April, 2017

N.V. Pradeep Kumar

N.V. Pradeep Kumar Alanki
Of Global IP Services
Registration number: IN/PA-1543

MULTI-SENSOR PATIENT MONITOR TO DETECT IMPENDING CARDIAC DECOMPENSATION

ABSTRACT

Systems and methods of detecting an impending cardiac decompensation of a patient measure at least two of an electrocardiogram signal of the patient, a hydration signal of the patient, a respiration signal of the patient or an activity signal of the patient. The at least two of the electrocardiogram signal, the hydration signal, the respiration signal or the activity signal are combined with an algorithm to detect the impending cardiac decompensation.

[Fig 1A]

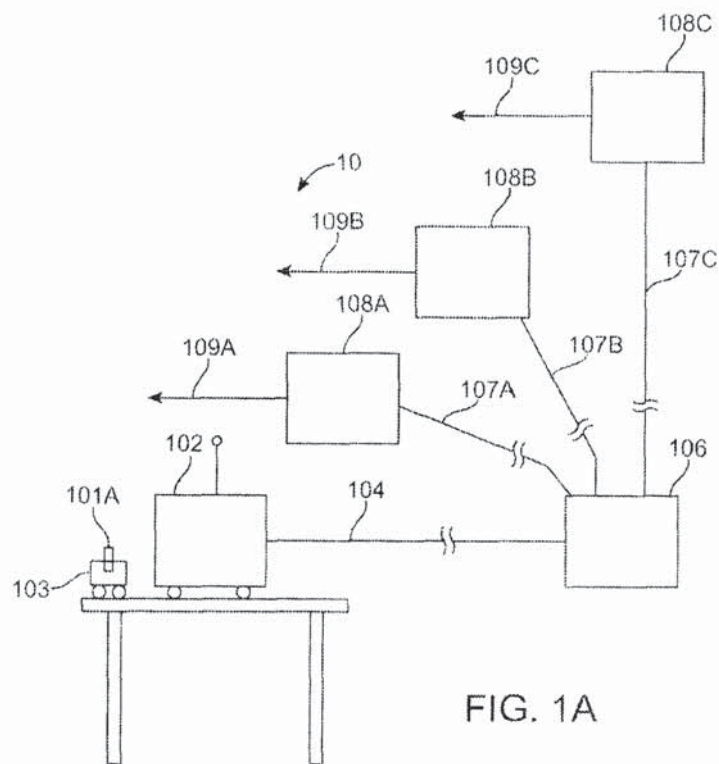
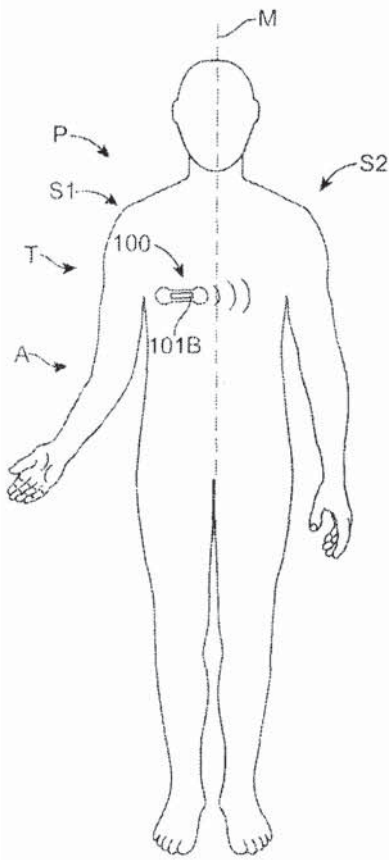

FIG. 1A

A.N.V Pradeep Kumar
N.V. Pradeep Kumar Alanki
Of Global IP Services
Registration number: IN/PA-1543

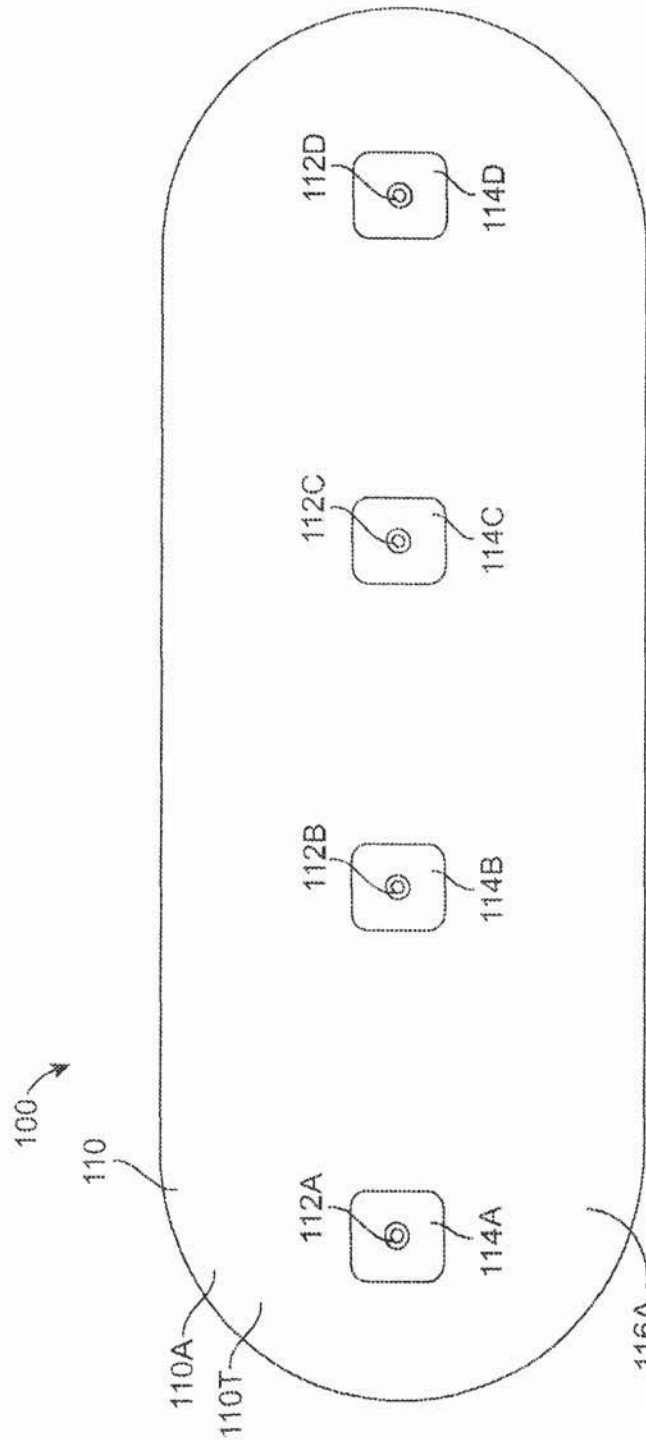

FIG. 1B

N.V. Pradeep Kumar
N.V. Pradeep Kumar Alanki
Of Global IP Services
Registration number: IN/PA-1543

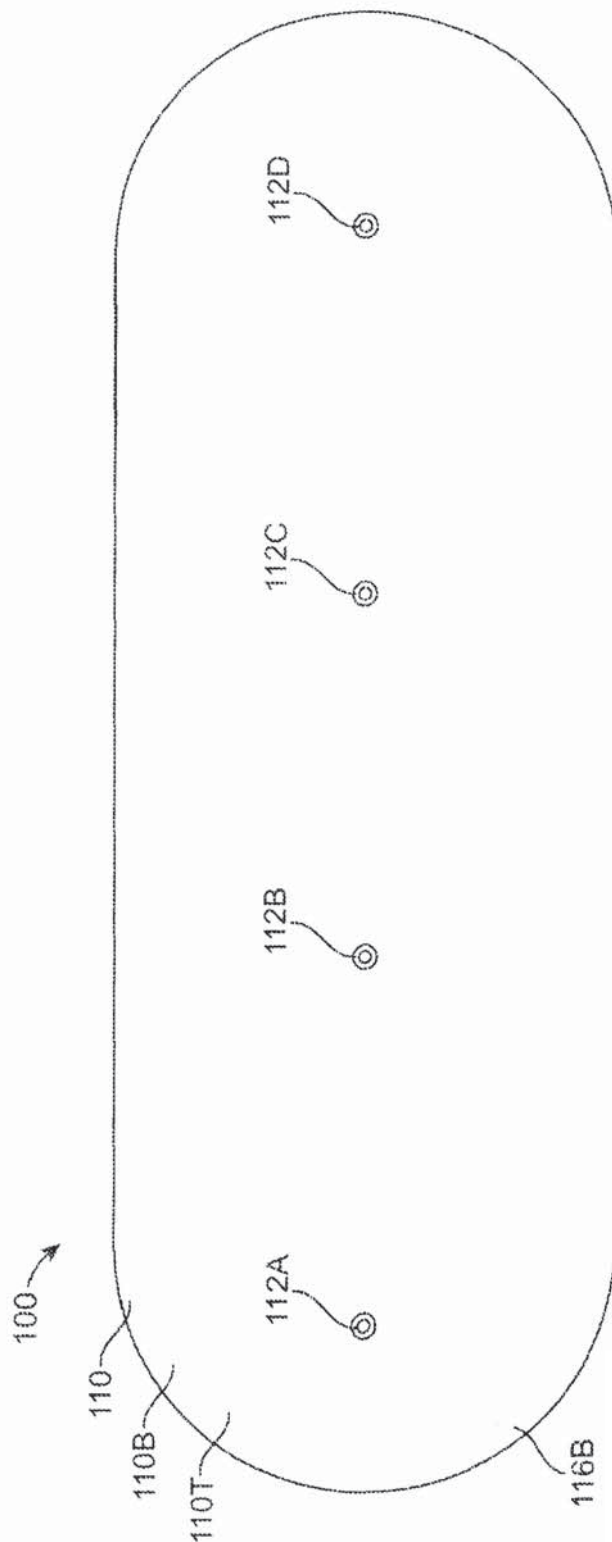

FIG. 1C

A.N.V. Pradeep Kumar
N.V. Pradeep Kumar Alanki
Of Global IP Services
Registration number: IN/PA-1543

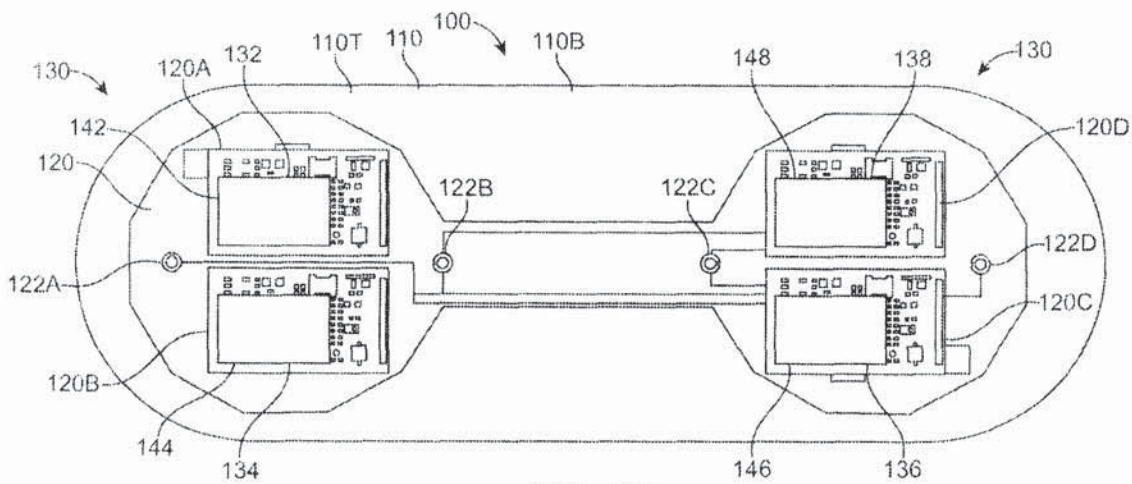

FIG. 1D

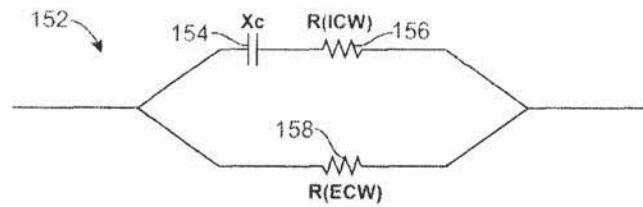

FIG. 1D-1

A.N.V Pradeep Kumar
N.V. Pradeep Kumar Alanki
Of Global IP Services
Registration number: IN/PA-1543

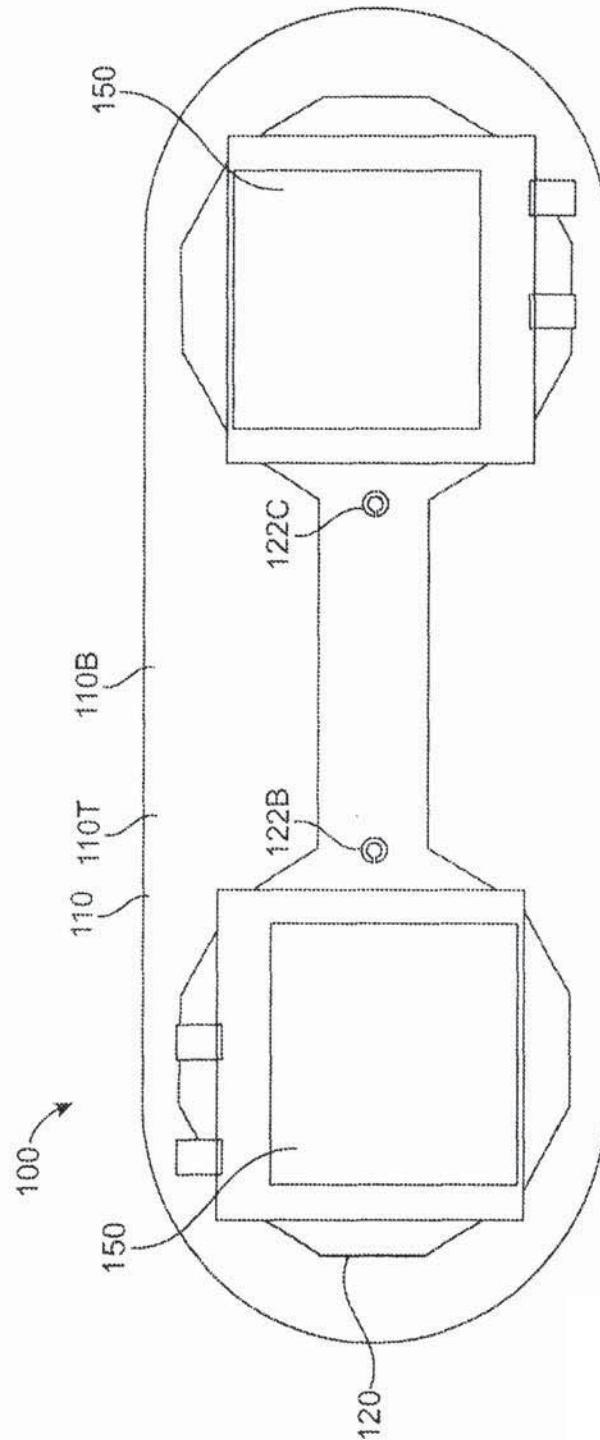

FIG. 1E

A.N.V Pradeep Kumar
N.V. Pradeep Kumar Alanki
Of Global IP Services
Registration number: IN/PA-1543

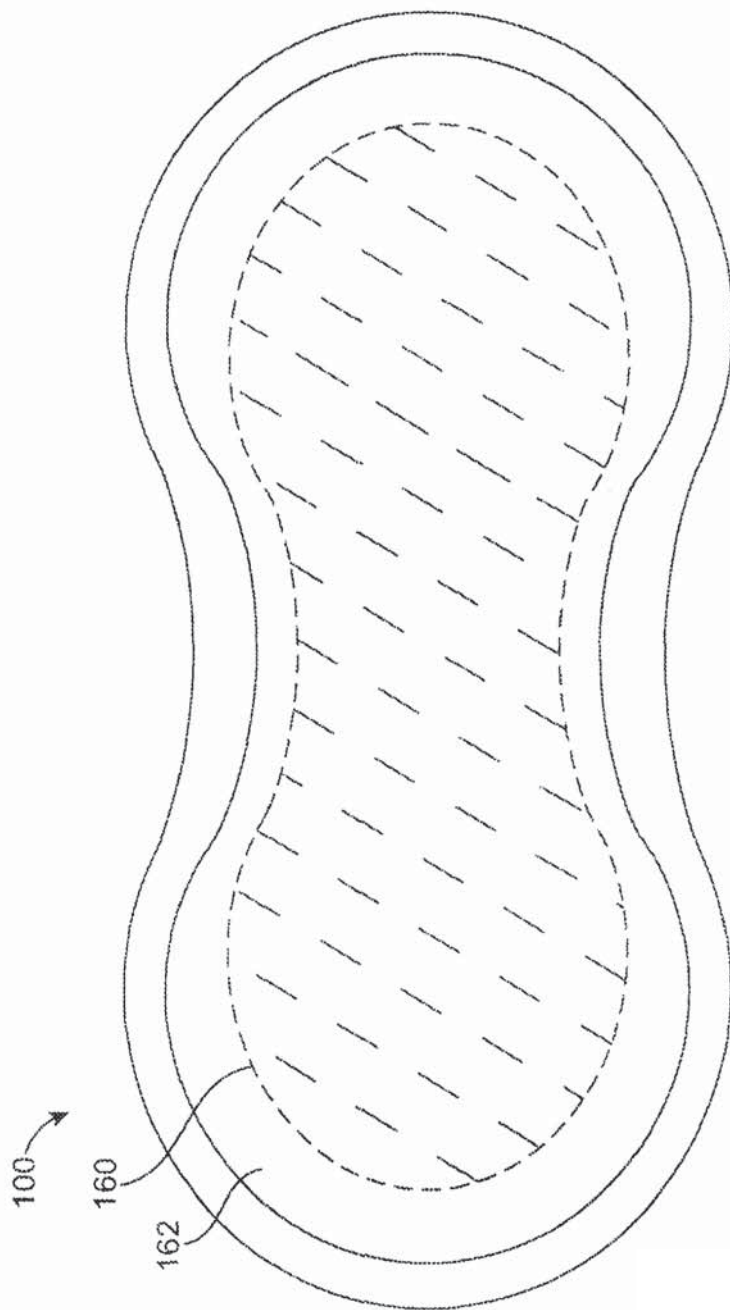

FIG. 1F

A.N.V Pradeep Kumar
N.V. Pradeep Kumar Alanki
Of Global IP Services
Registration number: IN/PA-1543

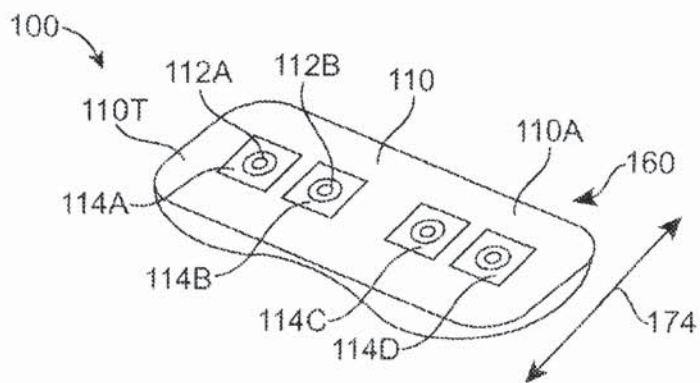

FIG. 1H

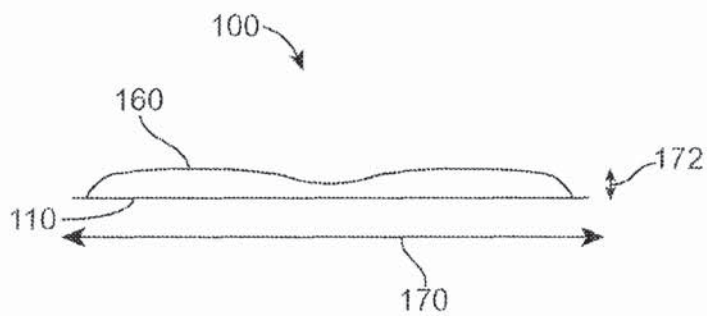

FIG. 1G

A.N.V. Pradeep Kumar
N.V. Pradeep Kumar Alanki
Of Global IP Services
Registration number: IN/PA-1543

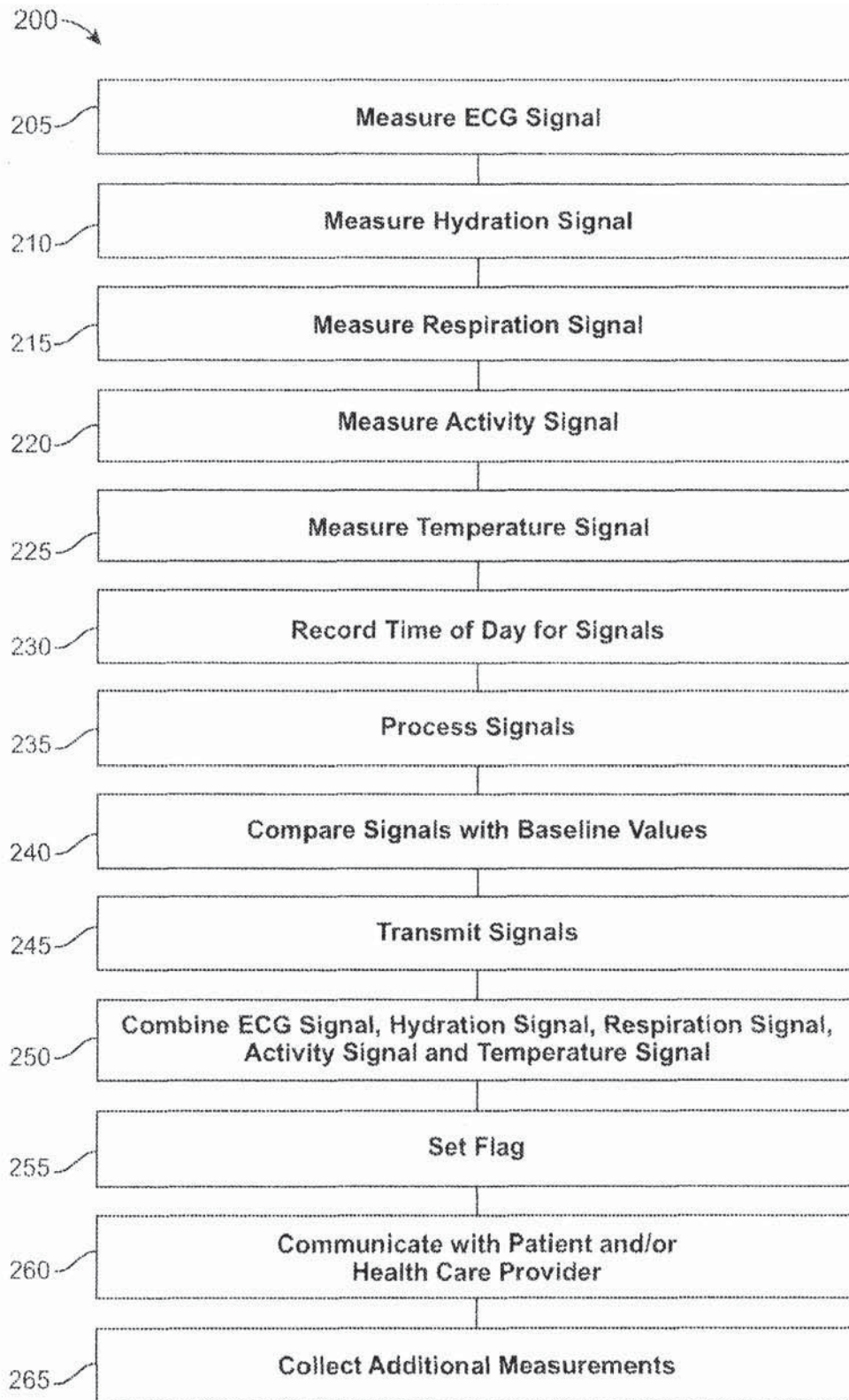

FIG. 2A

A.N.V Pradeep Kumar
N.V. Pradeep Kumar Alanki
Of Global IP Services
Registration number: IN/PA-1543

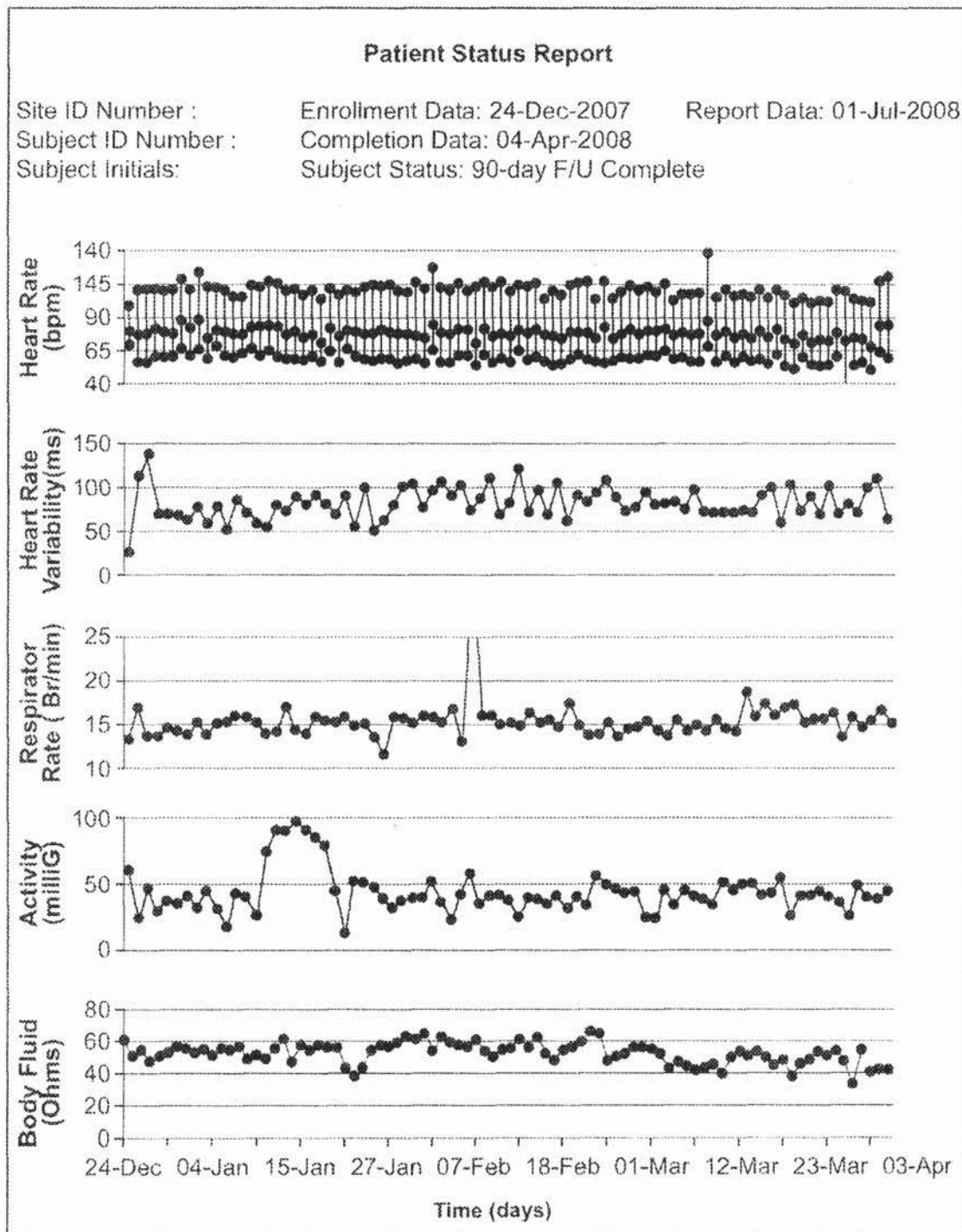

FIG. 3A

N.V. Pradeep Kumar
N.V. Pradeep Kumar Alanki
Of Global IP Services
Registration number: IN/PA-1543

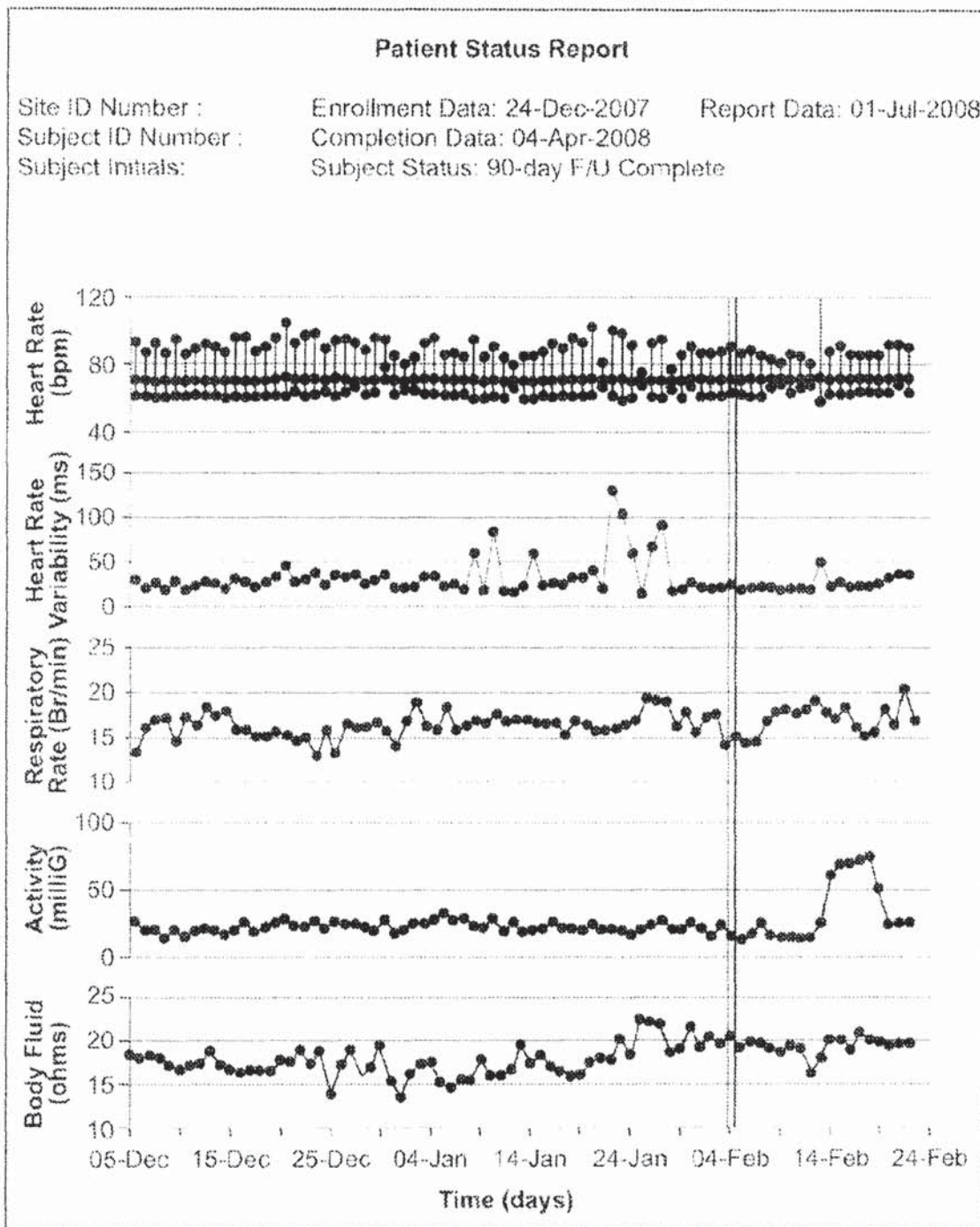

FIG. 3B

A.N.V Pradeep Kumar
N.V. Pradeep Kumar Alanki
Of Global IP Services
Registration number: IN/PA-1543